

# ST32 Twin Furnace

# 18000-40000 kg/hour

**Cochran's ST32 Low NO<sub>x</sub> packaged steam boiler is a horizontal three pass wet back design constructed in accordance with BS EN 12953. When fitted with compliant Cochran, or equivalent, combustion equipment, the boiler meets the latest European environmental legislation, the Medium Combustion Plant Directive (MCPD).**

It also complies with the requirements of the Factories Act (1961) and Guidance on Safe Operation of Boilers Ref: BG01 developed by the Safety Assessment Federation (SAFED) and the Combustion Engineering Association (CEA). In addition, the ST32 is UKCA, UKNI+CE or CE marked to meet the requirements of the Pressure Equipment Directive (PED), Low Voltage; Electro-Magnetic Compliance & Machinery Safety Directives. Throughout the manufacturing process, this boiler is subject to inspection by a leading Independent Insurance Company, in addition to Cochran's own ISO 9001-compliant quality procedures.

### **Cochran's ST32 packaged twin furnace steam boiler offers the following key features and optional upgrades:**

- UKCA, UKNI+CE or CE marked, horizontal three-pass, wet-back boiler design developed from Cochran's renowned Thermax range.
- Output range of 18000 kg/hr to 40000 kg/hr F&A 100°C at a nett efficiency of up to 95%.
- Designed and constructed in accordance with the latest European environmental legislation. BS EN 12953 and MCPD compliant, subject to other plant and equipment within the boilerhouse.
- Normal operating pressure 10 Barg, with options up to 30 Barg.
- Features Cochran's low NO<sub>x</sub> burners as standard.
- Wide range of combustion and control packages, superheater and economiser options.
- Turndown of up to 7:1.
- Cochran Eclipse or Synergy Touchscreen HMI with Modbus interface and remote access capability.
- Variable speed drives for FD Fan and Feed water pump motors help deliver low noise levels and reduce power consumption.
- Enhanced insulation for lower touch temperature.



# ST32 Twin Furnace

# 18000-40000 kg/hour

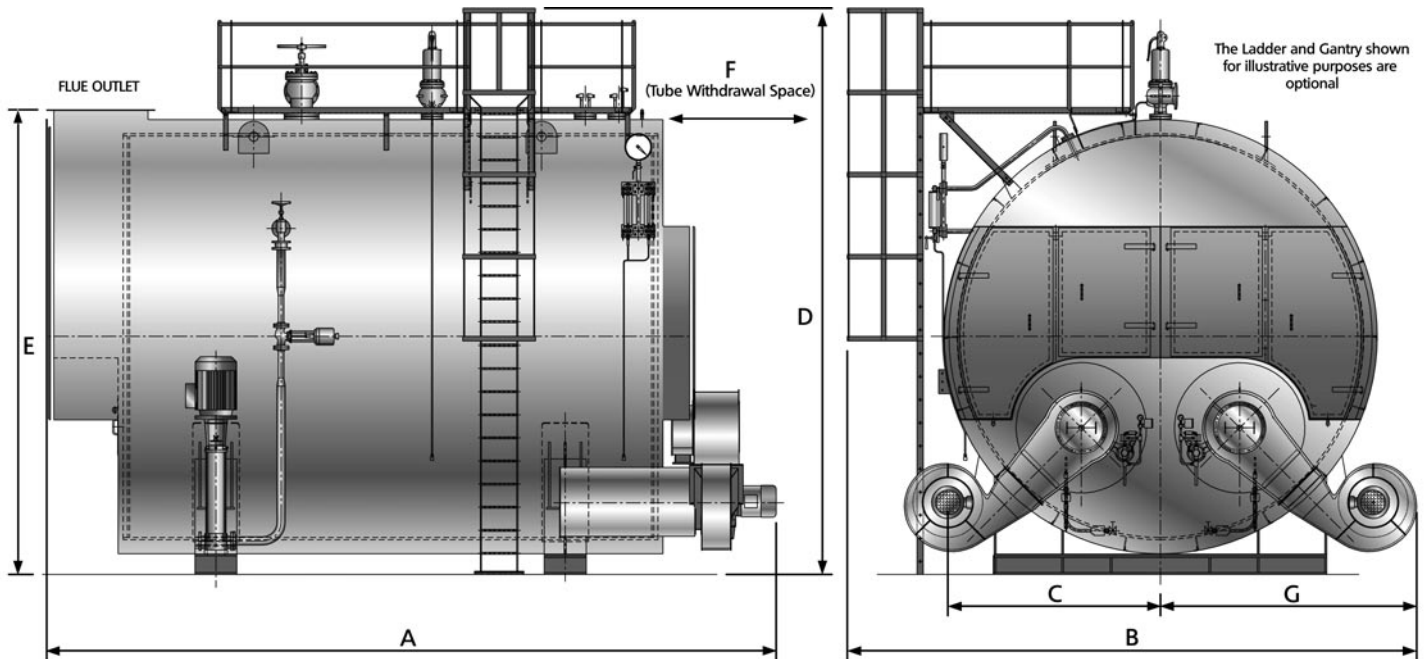

ST32 Boiler Model			ST32-18	ST32-20	ST32-22	ST32-5	ST32-27	ST32-30	ST32-32
F&A 100°C (212°F)		kg/h	18000	20000	22500	25000	27500	30000	32000
Dimensions	A	mm	7100	7250	7400	7610	7630	8330	8330
	B	mm	4061	4860	4980	5086	5225	5310	5475
	C	mm	1681	2095	2210	2286	2325	2360	2400
	D	mm	5335	5640	5745	5840	5940	6205	6355
	E	mm	4490	4535	4715	4850	4880	4900	5050
	F	mm	3625	3980	3980	4315	4335	4685	4685
	G	mm	2340	2765	2770	2800	2900	2950	3075
Min. Transport Width		mm	3362	4190	4420	4573	4650	4720	4800
Min. Transport Height		mm	3512	4340	4570	4725	4800	4870	4955
Rec. Chimney Dia.		mm	890	940	1016	1092	1168	1194	1220
Safety Valve Exhaust Dia.		mm	114	114	114	140	140	140	140
Steam Stop Valve Dia.		mm	230	250	250	300	300	300	300
Blow Down Valve Dia.		mm	50	50	50	50	50	50	50
Feed Water Inlet Dia.		mm	75	75	75	75	75	75	75
Boiler Weight-Empty		Tonnes	45.7	50.8	55.9	61	67	75.2	84.4
Boiler Weight-Full		Tonnes	86.7	96.6	106	113	127	142	158

**Note:** All Dimensions and weights are approximate only and are based on a boiler working pressure of 10 BarG.

**+44(0) 1461 202 111 [www.cochran.co.uk](http://www.cochran.co.uk)**

Newbie Works, Annan, Dumfries & Galloway, UK DG12 5QU.

Whilst this information is given in good faith, no warranty or representation is given concerning such information which must not be taken as establishing any contractual or other commitment binding upon Cochran Group Ltd Company or any of its subsidiary associated companies. ©2021 Cochran Ltd. Version 2 02/21

