



Planing and Sales

Phone: +49 (0)2151 578-235

Fax: +49 (0)2151 578-241

E-mail: verkauf@certuss.com

Service

Phone: +49 (0)2151 578-123

Fax: +49 (0)2151 578-251

E-mail: service@certuss.com

CERTUSS
Dampfautomaten
GmbH & Co. KG

Hafenstr. 65
D-47809 Krefeld

www.certuss.com

Contents

COMPANY HISTORY	1
OUR REFERENCES	2
HOW IT WORKS	3
JUNIOR TC	4
UNIVERSAL TC	6
ELECTRICAL E 6 – 72 M	8
ELECTRICAL E 100 – 120 M	10
CVE – CERTUSS VERIFIED EQUIPMENT	12
CVE ADVANTAGES	13
ECONOMIZER	14
CONTAINER	16
ADVANTAGES AT A GLANCE	18
CHECKLIST	19
CERTIFICATES	20

CERTUSS Company History

CERTUSS was established in 1957 in Krefeld, Germany when Hans Joachim Schroder set himself the goal of manufacturing **reliable, low-noise, compact** Steam Generators. These Generators were designed to be easy to maintain and applicable for **continuous operation**. Today CERTUSS are satisfying customers all around the globe with the help of sustainable, long-term partnerships. Trained and exclusive service partners in 35 countries are ready to assist you **anytime from everywhere**. We are market leader with more than **60% market share** in Germany, offering high quality **“made in Germany”** products.

Our companies focus lies on a **clearly defined product line, systematic R&D** and a team of **highly trained professionals** enabling equipment production of the **highest standards** complying with ASME and UL regulations, as well as ISO 9001-2015 and PED.

CERTUSS offers Generators requiring **little space** with capacities ranging from 53 kW to 1320 kW and operating pressures of up to 32 bar. To complete the Generator system, we offer our **CVE, CERTUSS Verified Equipment**, Package Plant Module where all associated ancillary items are pre-piped, pre-wired and factory tested. All Generators are equipped with a **touchscreen** simplifying control and operation. The thermal efficiency of CERTUSS Steam Generators ranges from **91% to 93%***. We offer various fuel types, liquidgas, natural gas, heating oil (EL) or a dual fuel burner for natural gas and heating oil (EL) for units above 328 kW. Full spare parts support is provided for each Generator for up to 20 years after commissioning and we hold electronic documentation of every Generator manufactured over the past 30 years.

Why you should chose CERTUSS? Check out all our advantages on page 18.

“Our history is the cornerstone that supports our current success, continue growth and allows us to push innovation in the future” Mathias K. Brauner, CEO, CERTUSS Germany



CERTUSS Steam Generator in 1957.



CERTUSS Steam Generator in 2015.

Our References

Thanks to our long company history we have had the privilege of working with many large and well-known companies and establishments from various industries.

CERTUSS Steam Generators have the advantage of being applicable in nearly **all industries**. We choose to keep our product line **clearly defined and scalable**.

We have gathered experience in **over 80 different sectors**, some of which are listed below, and have worked with diverse applications.

We have many customers in **service and hospitality** who use our Generators for chemical cleaning, disinfecting, laundering and other service purposes. For example we have installed Generators in many **Hyatt, Kempinski, Four Seasons** and **Holiday Inn Hotels**.

Another major sector we serve is the **healthcare sector**, including the chemical and pharmaceutical industry. CERTUSS Generators are applied in hospitals, cosmetics, plastics, mineral oil processing, pharmacies, and other chemical processes. Besides hospitals we have also worked with chemical and pharmaceutical companies, for example **B.Braun, Evonik, BASF, Merck, Procter & Gamble** or **Unilever**.

Additionally the **food and beverage** industry offers many applications for our Steam Generators. Examples are meat, milk, mineral water, soft drink, flavor, oils and sugar processes as well as alcoholic beverage, juice, coffee, tea productions or luxury food goods like candy, tobacco products or pralines. In this sector CERTUSS Generators are used by, for example, **Coca-Cola Companies, Dr. Oetker Frozen Foods** as well as **Nestle Group**.

Finally, diverse companies from the **automotive, construction and mechanical engineering** sector have purchased CERTUSS Generators for use in sanitation, ceramics and glass, cement production, heating, and woodworking. **Samsung Germany, Siemens, Philips Components** are customers we have served to this day.

With all the German **car manufacturers** located in our home country CERTUSS has had the possibility to work for **Volkswagen, Mercedes Benz** and **BMW**.

All that is left to say now is that if you like German cars, you'll **love** our Generators!



By using the **water tube boiler** principle, the CERTUSS technology for generating steam offers **maximum safety, reliability and instant availability of high quality steam**.

- 1** The **touch screen control panel** simplifies operation and control of the generator. All configurations and settings of steam pressure are made here.
- 2** The **pre-heated feed water** is delivered to the Generator at approx. 90 to 95 °C. The heat frees the oxygen from water and reduces the risk of oxygen corrosion.
- 3** The **heat exchanger** coil is supplied with water through the feed water inlet. The change of phase from water to steam begins.
- 4** The modulating, **integral burner** with the fastest response time, provides precise steam pressure control down to 1/10 bar.
- 5A** Insulation material is made obsolete by guiding the **combustion air** from the top of the Generator through an outer shell, and from there into an inner, secondary shell.
- 5B** The **combustion air intake & fan** draw in warm air through the triplex system to preheat the combustion air and keep the outer jacket cool.
- 6** When the steam has been produced, it leaves the generator through the **steam outlet** and is then ready for use.
- 7** The **flue gas outlet** connects to the chimney with or without an Economizer.
- 8** Sediment is flushed out through the **steam generator coil blowdown valve**.
- 9** The **safety relief valve** opens automatically to discharge excess steam when the pressure is too high.

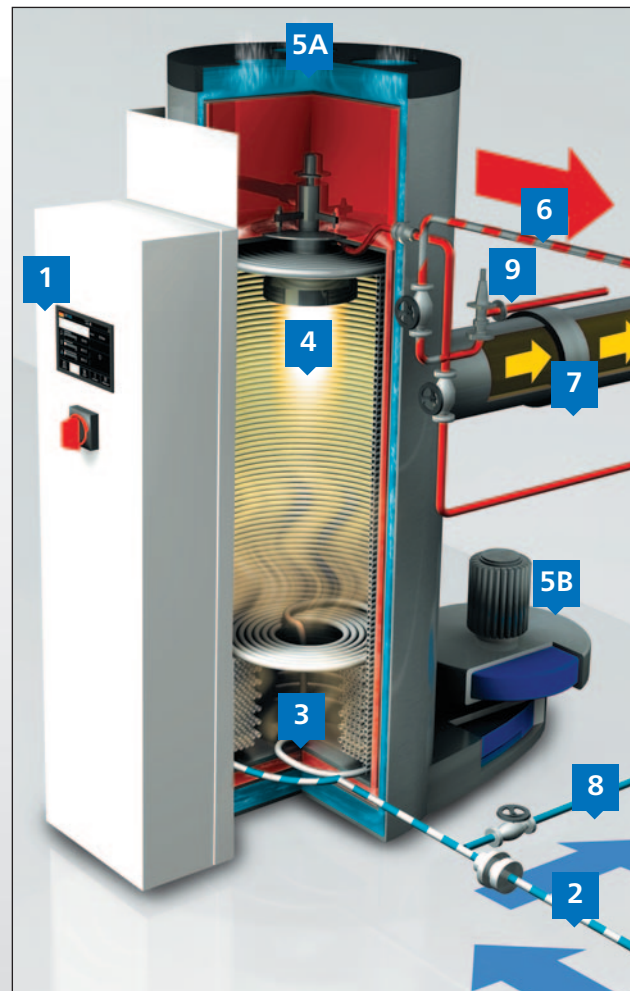

Junior TC 80 – 400

The Junior TC series includes the smaller sized Generators for customers who require low amounts of steam. All Junior TC Generators are equipped with an easy to use **touchscreen panel** that simplifies operation. They are our most space saving steam solutions. They can serve constant and fluctuating demands in steam, with steam available in **under 5 minutes**.

Features

- Space saving
- Installation without foundation support
- Robust steel construction
- Triplex air insulation creates good air circulation within the generator and preheats the combustion air
- Integrated, 1st stage CERTUSS burner system
- Noise and vibration reduction, anti-vibration mountings
- Economical fast energy transfer reducing radiation losses
- Vertical expansion free centrally suspended heating coil with bottom blowdown
- Replaceable evaporation section
- Easy and quick cleaning of the heating system, without removal
- Fully automated operation
- Exemplary customer service and spare parts availability 24 / 7 / 365
- Thermal Efficiency up to 98% (with the use of an Economizer)
- Full adjustable output of steam
- BMS compatibility with Profibus/CANbus, Modbus, BACnet etc.,
- 7" Touch Control (TC) screen



Reference values: Natural gas 10 kW/Nm³ - 8600 kcal/Nm³, liquid gas 25,8 kW/Nm³ - 22200 kcal/Nm³. Dimensions and weights have been rounded up or down. MPa and bar are overpressure values. Performance values referenced to 100 °C feed-water temperature and 1 MPa (10 bar) steam overpressure. CERTUSS burner with flue-gas recycling (NO_x reduction).

1. Junior TC Steam Generator
2. CVE Utility Unit
3. Pre Pressure Pump
4. Feed Water Pump
5. Feed Water Tank
6. Blowdown Vessel
7. Chemical Dosing
8. Water Softening Plant
9. Brine Tank
10. Control Panel
11. Steam Separator
12. Water Filter

- DA. Steam Connection
 WA. Water Connection
 SL. Tank Vent (To Atmos)
 SV. Safety Valve (To Atmos)
 KA. Drain Connection
 KD. Condensate Connection
 BA. Fuel Connection

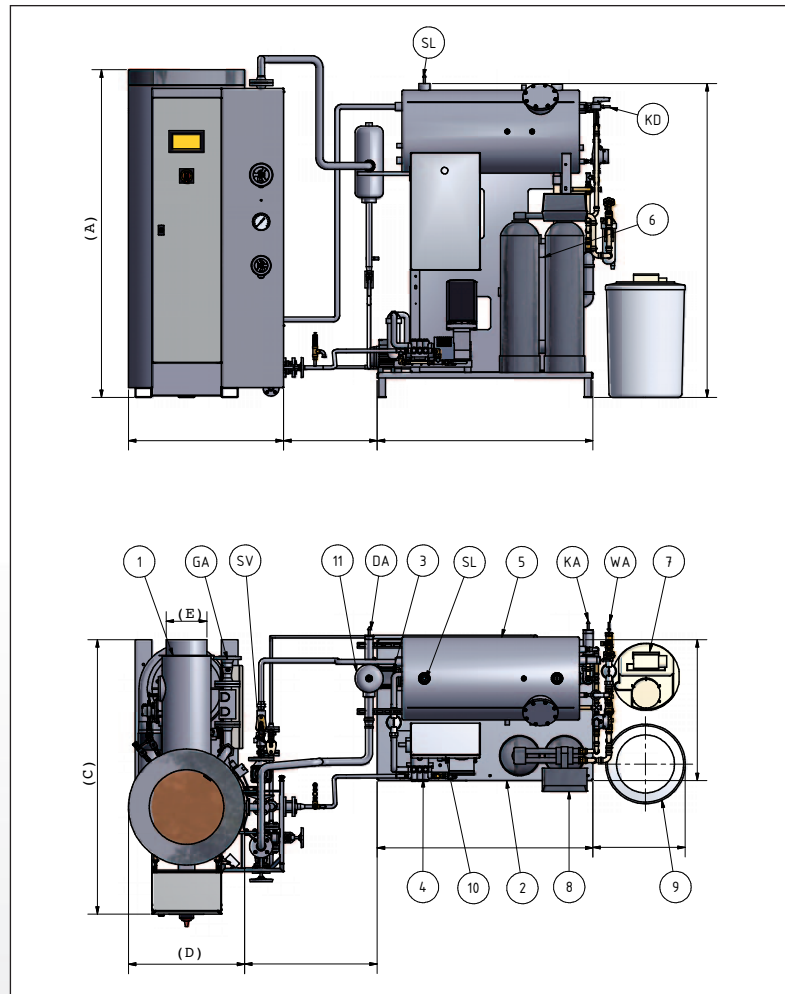

Model Junior	Capacities			Pressures		Consumption			Dimensions (~ mm)						Weight (~ kg)
	Steam capacity kg/h	Heating capacity kW	Nominal load kW	Max. operating pressure MPa (bar)	Max. permissible overpressure MPa (bar)	Heating oil (EL) kg/h	Natural gas m³/h	Liquid gas m³/h	Height A	Width B	Depth C	Boiler Ø D	Flue gas pipe Ø E	Flue gas (center) F	
80	80	53	58	0,8 – 2,9	1 – 3,2	4.9	5.8	2.2	1515	730	1295	500	180	1050	320
120	120	80	87	(8 – 29)	(10 – 32)	7.4	8.7	3.4							
150	150	100	109	0,8 – 2,9	1 – 3,2	9.2	10.9	4.2	1600	770	1475	560	200	1120	420
200	200	133	145	(8 – 29)	(10 – 32)	12.3	14.5	5.6							
250	250	167	182	0,8 – 2,9	1 – 3,2	15.3	18.2	7.1	1850	875	1580	640	250	1360	520
300	300	201	218	(8 – 29)	(10 – 32)	18.4	21.8	8.4							
350	350	235	255			21.5	25.5	9.9							
400	400	268	291			24.5	29.1	11.3							

Specifications subject to be changed

Universal TC 500 – 2000

The Universal TC series is equipped to serve constant, as well as fluctuating, **high steam** demands making these Generators our most high performing solutions. Due to an extremely short heat up time, steam is available after **less than 5 minutes**. The touch screen control panel facilitates operation and gives a bundled overview of current pressures and configurations. Additionally the Generator can easily be operated remotely.

Features

- Space Saving
- Installation without foundation support
- Robust steel construction
- Triplex air insulation creates good air circulation within the generator and preheats the combustion air
- Integrated, 1st stage CERTUSS burner system
- Noise and vibration reduction, anti-vibration mountings
- Economical fast energy transfer reducing radiation losses
- Vertical expansion free centrally suspended heating coil with bottom blowdown
- Replaceable evaporation section
- Easy and quick cleaning of the heating system, without removal
- Fully automatic operation
- Exemplary customer service and spare parts availability 24 / 7 / 365
- Thermal Efficiency up to 98% (with the use of an Economizer)
- Full modulation from 50% to 100% (natural gas, liquid gas)
- BMS compatibility with Profibus/CANbus, Modbus, BACnet etc.,
- 7" Touch Control (TC) screen



Reference values: Natural gas 10 kW/Nm³ - 8600 kcal/Nm³, liquid gas 25,8 kW/Nm³ - 22200 kcal/Nm³. Dimensions and weights have been rounded up or down. MPa and bar are overpressure values. Performance values referenced to 100 °C feed-water temperature and 1 MPa (10 bar) steam overpressure. CERTUSS burner with flue-gas recycling (NO_x reduction).

1. Universal TC Steam Generator
2. CVE Utility Unit
3. Pre pressure pump
4. Feed Water Pump
5. Feed Water Tank
6. Blowdown Vessel
7. Chemical dosing
8. Water softening plant
9. Brine Tank
10. Control panel
11. Steam separator
12. Water filter

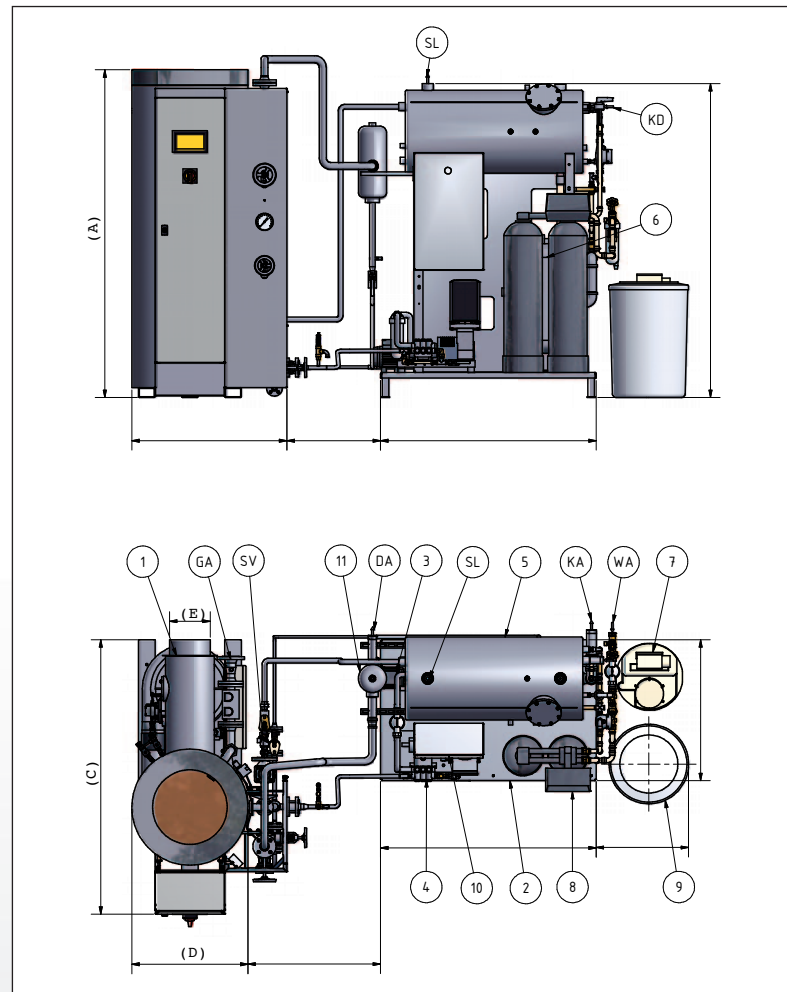

- GA. Fuel
 SV. Safety Valve
 DA. Steam
 SL. Tank Vent
 KA. Drain
 WA. Water
 KD. Condensate

Model Universal	Capacities			Levels	Pressures		Consumption			Dimensions (~ mm)						Weight (~ kg)
	Steamcapacity kg/h	Heating capacity kW	Nominal load kW		Max. operating pressure MPa (bar)	Max. permissible overpressure MPa (bar)	Heating oil (EL) kg/h	Natural gas m ³ /h	Liquidgas m ³ /h	Height A	Width B	Depth C	Boiler Ø D	Flue gas pipe Ø E	Flue gas (center) F	
500 600	500 600	335 401	364 436	2	0,8–2,9 (8–29)	1–3,2 (10–32)	30.6 36.8	36.4 43.6	14.1 16.9	1985	955	1725	700	250	1460	950
700 850	700 850	469 619	510 619	2	0,8–2,9 (8–29)	1–3,2 (10–32)	42.9 52.1	50.9 61.8	19.7 24.0	2290	1160	1930	870	300	1750	1100
1000 1300	1000 1300	670 871	728 947	2	0,8–2,9 (8–29)	1–3,2 (10–32)	61.3 79.7	72.7 94.5	28.2 36.7	2535	1275	2125	1000	350	1940	1500
1500 1800 2000	1500 1800 2000	1006 1206 1320	1093 1311 1454	2	0,8–2,9 (8–29)	1–3,2 (10–32)	91.9 110.3 122.6	109.1 130.9 145.4	42.4 50.8 56.4	2675	1420	2415	1100	500	2025	2300

Specifications subject to be changed

Electrical E 6 – 72 M

The electric Steam Generators E6-72M are characterised by their short heat-up times and low space requirement. Their construction method has proven itself as reliable and efficient over many decades. The E6-72M offers immediate output adjustment, simplified operation and highly simplified maintenance. The steam output of these Generators ranges between 8 kg/h and 97 kg/h.

Features

- Compact and space saving
- Fits through all norm doors
- Direct access from the front for easy maintenance
- Steam available quickly
- Electrical heating elements made of stainless steel with large heating surface
- Fully automatic operation possible
- Function and malfunction indications can be linked to central control system /building services control system provided by customer
- Exemplary customer service and spare parts availability 24/7/365
- Can be installed in work areas
- Spare parts available up to 20 years
- On request, all boiler parts can be made of stainless steel for pure steam production



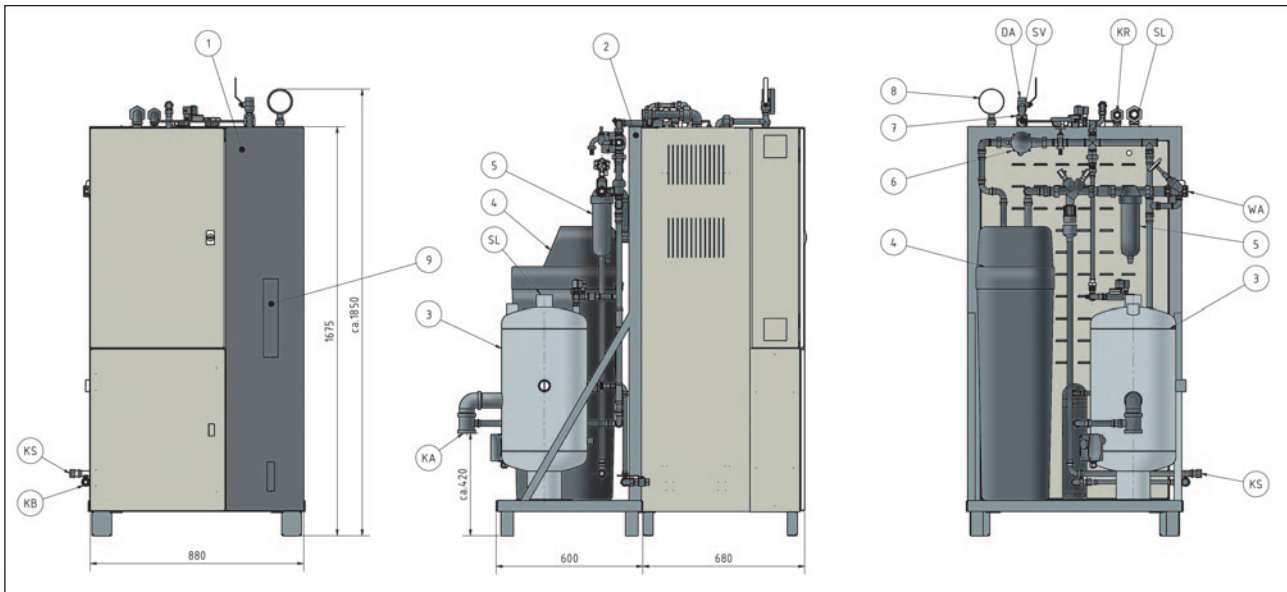

- | | | |
|-------------------------------------|---|-----------------|
| 1. Electric Steam Generator E 6-72M | 7. Safety valve | SL. Vent Outlet |
| 2. Utility unit CVE E 6-72M | 8. Manometer | WA. Water |
| 3. Mixing cooler 50 ltr. | 9. Roller indicator level regulator / limiter | KR. Condensate |
| 4. Water softening plant | DA. Steam | KS. Drain |
| 5. Water filter | KA. Drain | KB. Blowdown |
| 6. Water meter | SV. Safety Valve | |

Technical Data E 6 – 72 M		E 6 M	E 12 M	E 16 M	E 18 M	E 22 M	E 24 M	E 28 M	E 32 M	E 36 M	E 40 M	E 48 M	E 56 M	E 64 M	E 72 M
Steam output	kg/h	8	16	21	24	29	32	37	42	48	53	64	75	86	97
Heat output	kW	6	12	16	18	22	24	28	32	36	40	48	56	64	72
Power Stages		1-Stage			2-Stages						3-Stages				
Electrical Connection up to 0.6 MPa (6 bar) up to 1.2 MPa (12 bar)	kW	6.8	12.8	16.8	18.8	22.8	24.8	28.8	32.8	36.8	40.8	48.8	56.8	64.8	72.8
		7.8	13.8	17.8	19.8	23.8	25.8	29.8	33.8	37.8	41.8	49.8	57.8	65.8	73.8
Operating Voltage		3 x 400 V/ 50 Hz													
Admissible Pressure	MPa	0.6 / 1.0 / 1.2													
	bar	6 / 10 / 12													
Working Press min./max.	MPa	0.35 – 0.55 / 0.35 – 0.8 / 0.35 – 1.1													
	bar	3.5 – 5.5 / 3.5 – 8.0 / 3.5 – 11													
Water Capacity	ltr.	28													
Dimensions H x W x D	mm	1850 x 880 x 680 (depth including mounting approx. 785 mm)													
Empty weight approx.	kg	320													
Connections	DN	Water vapour 1" / Feed water 1/2" / Steam 1/2" / Safety Valve blow-off line 1" / Condensate 3/4"													

Electrical E 100 – 120 M

The electric Steam Generator E 100 – 120 M is characterized by its short heat-up time, low space requirements and simplified service. Its losses are low and it offers immediate output adjustment. The steam output of this Generator ranges between 135 kg/h and 160 kg/h.

Features

- Compact and space saving
- Direct access from the front for easy maintenance
- Steam available quickly
- Electrical heating elements made of stainless steel with large heating surface
- Fully automatic operation possible
- Function and malfunction indications can be linked to PLC/ central control system provided by customer
- Exemplary customer service and spare parts availability 24/7/365
- Can be installed in work areas
- Spare parts available up to 20 years
- On request, all boiler parts can be made of stainless steel for pure steam production



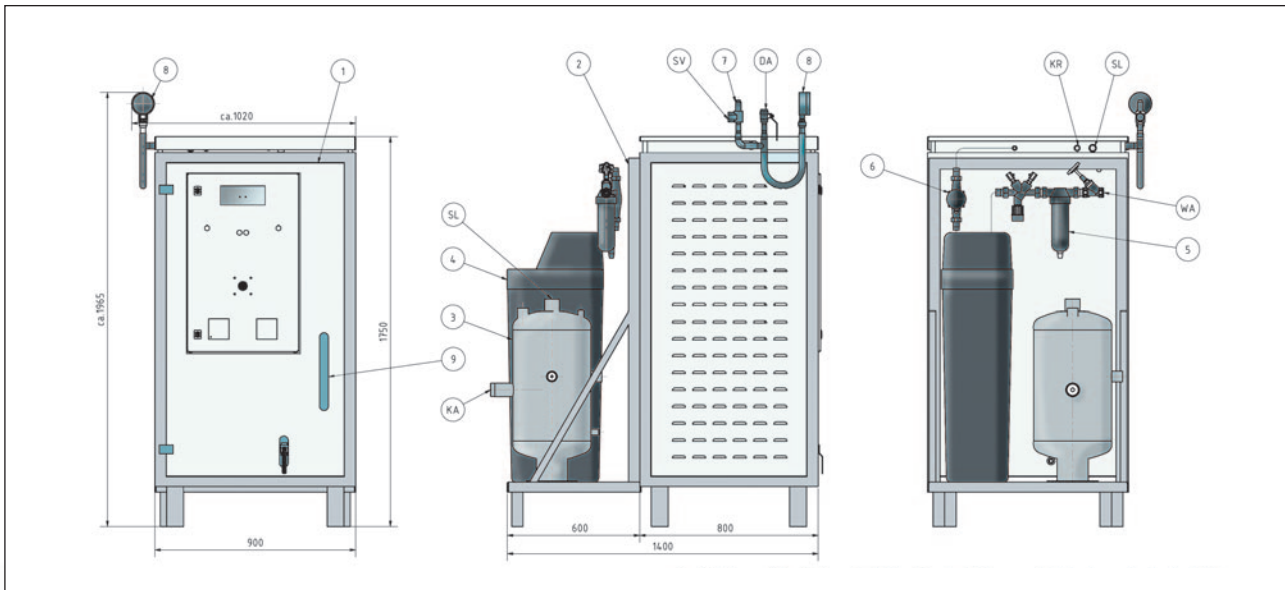

- | | | | |
|---|--------------------------|---|------------------|
| 1. Electric Steam Generator E 100 – 120 M | 4. Water softening plant | 8. Manometer | SV. Safety Valve |
| 2. Utility unit CVE E 100 – 120 M | 5. Water filter | 9. Roller indicator level regulator / limiter | SL. Vent Outlet |
| 3. Mixing cooler 50 ltr. | 6. Water meter | | WA. Water |
| | 7. Safety valve | DA. Steam | KR. Condensate |
| | | | KA. Drain |

Technical Data E 100 – 120 M		Measurements, weights and further values are rounded up. Indicated pressure are overpressure values. Output values stated are related to 10°C feed water temperature and 0.6MPa (6 bar) steam overpressures. Delivery complete including stainless steel water feed tank. Rights reserved for technical alterations.	
Steam output	kg/h	135	160
Heat output	kW	100	120
Electrical Connection	kW	105	125
Operating Voltage		3 x 400 V/ 50 Hz, alternative voltage on request	
Admissable Pressure	MPa	Optional equipment 0.6 / 1.0 / 1.2 (6 / 10 / 12 bar)	
Working Press max.	MPa	0.5 / 0.8 / 1.0 (5 / 8 / 10 bar)	
Water Capacity	ltr.	38.8	
Dimensions H x W x L	mm	1925 x 1005 x 800	
Empty weight approx.	kg	415	
Connections	DN	Vent 1" / Feed water 1/2" / Steam 1/2" / Safety Valve blow-off line 1" / Condensate 3/4"	

CVE – CERTUSS Verified Equipment for Junior & Universal TC

The **CVE** supply unit combines all components needed to supply the Steam Generator in one compact body. Instead of having to combine many single parts, our CVE offers all **necessary add-on's** for supply and water treatment in one. Thereby complex on-site installations are obsolete and factory-tested functional reliability is assured.

Features

- Duplex water softening plant including Automatic dosing
- Brine tank
- Feed water tank with pre-heater
- Steam separator
- Blow-Down Vessel with automatic after cooler
- Control Panel
- Blowdown heat recovery system
- Pre -Pressure Pump
- Testomat; conductivity monitor

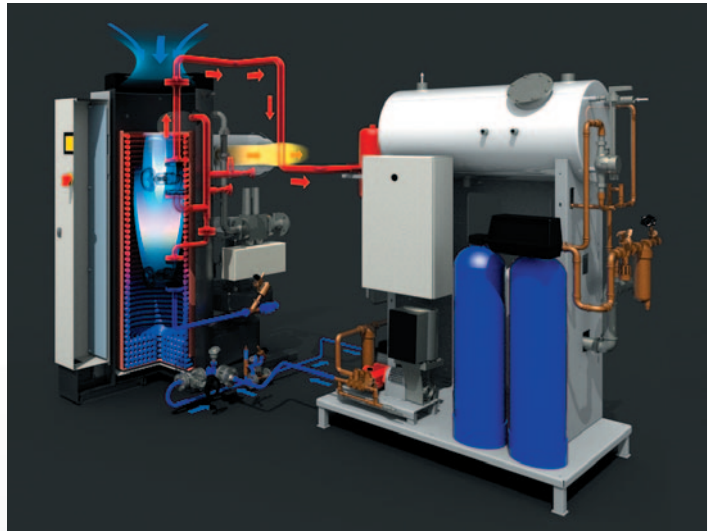

- All supply and water treatment components for CERTUSS Steam Generators are supplied as a single unit and are CERTUSS verified.
- Fast, economical commissioning, ready for operation
- Easy maintenance access
- Enhanced safety due to factory pre-installation of water, steam and electrical connections
- Less space required due to compact design
- Simple on site single point installation
- Complete with electrical sub distribution
- Durable galvanized base frame
- Use of approved, high quality materials
- 3D drawings available for easy design and layout



Model	For Steam Generators with steam output kg/h	Dimensions (mm)			Connections				
		Height	Width	Depth	Raw Water DN	Waste Water DN	Rinsing Water (softening) DN	Ventilation (feed water tank) DN	Condensate DN
Junior	80 – 120	1950	1300	850	1"	2"	1/2"	2"	1 1/4"
	150 – 200								
	250 – 400								
Universal	500 – 600	2300	1700	1200	1"	2"	1/2"	DN 100	1 1/2"
	700 – 850								
	1000 – 1300								
	1500 – 2000								
Multiple Units	2 x 80 – 120	2300	2200	1200	1"	2"	1/2"	2"	1 1/4"
	2 x 150 – 200								
	2 x 250 – 400								
	2 x 500 – 600								

Specifications subject to be changed

CERTUSS Economizer CERTECON 80 – 650

An innovative solution for saving energy during operation of the oil- or gas-heated CERTUSS Steam Generators of the Junior 80 – 400 series and the Universal 500 – 600 series.

Depending on the output level, operating pressure and utilization of the Steam Generator, the combustion-specific degrees of thermal efficiency increases to up to **5%**.

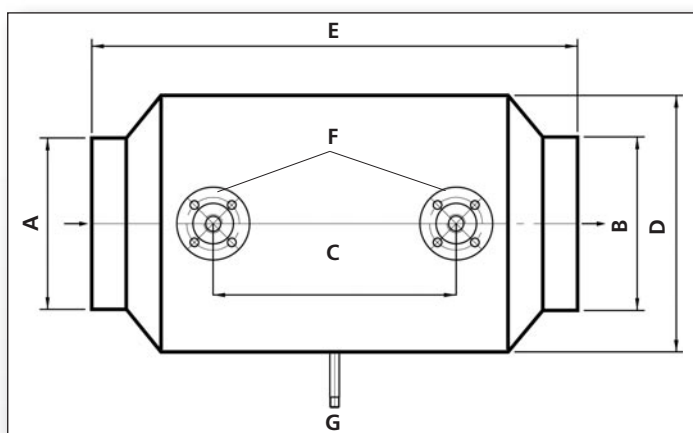

CERTECON		80 – 120		150 - 200		250 - 650					
CERTUSS Steam Generator	Type	Junior								Universal	
		80	120	150	200	250	300	350	400	500	600
A Flue gas inlet Ø internal	mm	180		200		250					
B Flue gas outlet Ø external	mm	178		198		248					
C Connecting piece distance	mm	220		270		350					
D Height	mm	250		280		370					
E Width	mm	590		640		740					
F Water inlet / outlet PN 100	DN	15				20					
G Drain flue gas condensate	DN	1/2"									
* Heat output at full load up to	kW	0,9	1,5	1,5	4,0	4,0	4,5	5,0	5,5	6,0	7,0
Weight without water	kg	24		33		66					
Water capacity	Ltr.	0,91		1,99		3,86					
** Operating overpressure max.	bar	10 - 40		10 - 13	16 - 32	40	10 - 32			40	

* The values can deviate depending on the operating pressure, connected burner output and degree of utilization of the steam generator.

** Select the operating overpressure as at the associated steam generator.

Rights reserved for technical alterations.

CERTUSS Economizer CERTECON 500 – 2000

The CERTUSS Economizer increases the degree of **generator efficiency** and reduces CO² emissions for generator systems fired by **natural gas or light oil**. As flue gas heat exchanger, it uses exhaust gas heat to increase the temperature of the boiler feed water and reduces fuel use by up to **5%** and gains efficiency up to 5%.

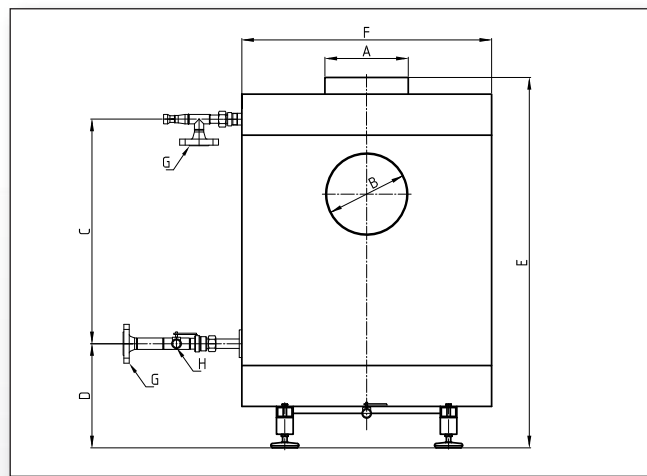

CERTECON		700 - 960		1000 - 1300		1000 - 2000		
CERTUSS Steam Generator Type Universal		700 – 850		1000 – 1300		1500 – 2000		
A	Flue gas inlet Ø internal	mm	300	350	500			
B	Flue gas outlet Ø external	mm	295	345	495			
C	Connecting piece distance	mm	850	900	940			
D	Distance floor / connecting piece	mm	355					
E	Height	mm	1325	1385	1450			
F	Diameter	mm	900	1020	1100			
G	Water inlet / outlet PN 100	DN	25		32			
H	Blowdown	DN	15		25			
I	Dewatering flue gas condensate		3/4"					
*	Heat output at full load up to	kW	15	25	43			
	Weight without water	kg	320	387	442			
	Water capacity	Ltr.	43,1	51,6	71,6			
**	Operating overpressure max.	bar	10 – 32	40	10 – 32	40	10 – 32	40

* The values can deviate depending on the operating pressure, connected burner output and degree of utilization of the steam generator.

** Select the operating overpressure as at the associated steam generator.

Rights reserved for technical alterations.

Containerized Package Plant

The CERTUSS **fully equipped container unit** is our solution in case isolation from the rest of your plant is required. It contains all components necessary to operate an entire plant.

After connecting the main services and commissioning, steam is at your disposal in **less than 5 minutes**. The self contained unit is **flexible**, allowing permanent, as well as temporary positioning.

On inquiry we can take over full or partial installation of the steam system. If you choose to contract out to other companies, we can carry out consultation and supervision for your containerized unit.

Features

- Steam Generator(s)
- CVE supply unit
- Softening plant
- Pressure reducing station
- Steam distribution header
- Blowdown vessel with automatic after cooler
- Steam separator
- Condensate header
- Emergency stop switch
- ...and more



Container Advantages

- Customizable
- Space saving
- Complete installation of both Mechanical and Electrical components, leaving only site service connections to be made
- Fully insulated walls for protection of equipment against adverse weather conditions
- High grade steel walls internally and externally
- European standard paint finish to customer specification
- Fully insulated pipe services internally of the container
- Optional steel door or UPVC door to suit customer specification
- Full internal lighting
- Full internal heating
- Flexible for temporary or permanent location positioning; Mobile unit
- Removes requirement for separate boiler-house
- Allows customer full usage of valuable process floor space
- Access space for maintenance work is fixed
- Reduced costs for site installation work



All advantages at a glance

- Start-up time of **3 – 5 minutes** with steam available
- **Minimal floor requirement**
- Up to **98% thermal efficiency***
- Reduced corrosion due to **vertical** orientation
- Low water carrier equals **safe operations**
- **Fully automated, unmanned operation** available
- Silent operation, less than **75 dBa sound pressure**
- Reduction of piping costs due to **decentralized** plants
- **7" Touchscreen** display
- Remote access via **Ethernet, Wi-Fi or GSM (Cellular)**
- Remote maintenance and control possible with **iPad or iPhone**
- Predictive maintenance: informing of potential issues **before** they occur
- Redundancy with **multiple plant solution**
- Mildly warm operating generator due to **triplex air insulation vessel**
- Minimal and easy maintenance with spare parts available **up to 20 years**
- **24/7/365 aftersales support**
- **Less pollution** through low water drainage



Reference values: Natural gas 10 kW/Nm³ - 8600 kcal/Nm³, liquid gas 25,8 kW/Nm³ - 22200 kcal/Nm³. Dimensions and weights have been rounded up or down. MPa and bar are overpressure values. Performance values referenced to 100 °C feed-water temperature and 1 MPa (10 bar) steam overpressure. CERTUSS burner with flue-gas recycling (NO_x reduction).

1. Do you want **quick start-up times** and steam almost **instantaneously**?
2. Do you have a boiler constantly in hot **standby** mode?
3. Do you want to be more **environmentally friendly**?
4. Do you experience **fluctuations** in steam demand?
5. Do you have **limitations in space** or want to use your space more **efficiently**?
6. Do you want to operate your generator **remotely** without having an operator on site all the time?
7. Do you currently have an **aging** boiler?
8. Do you face difficulties obtaining **replacement** and **spare parts** for your boiler?
9. Do you experience efficiency losses due to long **distances** between the **production** and the **use** of steam?
10. Do you prefer a **point of use** steam source?
11. Do you have **maintenance** issues with your current boiler?
12. Do you have confidence in the **quality and reliability** of your existing boiler?

If you checked **4** or more of these questions you should consider buying a new, high efficiency steam generator by **CERTUSS!**

Please contact us for a non-binding offer!

Certificates



Customer Installations



Food & Beverage



Laboratories



Healthcare



Mechanical Engineering



Service Industry



CERTUSS Dampfautomaten GmbH & Co. KG

Hafenstraße 65 | D-47809 Krefeld
Phone: +49 (0)2151 578-0 | Fax: +49 (0)2151 578-102
www.certuss.com | krefeld@certuss.com