

Mini Mk8 Controller

## Complete burner management in a compact, affordable system

The Mini Mk8 is a cutting-edge Micro-Modulating system that provides an easily programmable and flexible means of optimising combustion throughout the load requirement range of the boiler/burner.

This control module encompasses all the functions required for reliable burner management. Built into this system is a fully automated flame safeguard and valve proving system, MODBUS connectivity, and a new touchscreen interface.

This system ensures the burner temperature is accurate to within 1° and pressure to within 1 PSI. The positioning accuracy of the direct drive motors controlling the air damper and fuel valve is 0.1 angular degrees throughout the load range. This accuracy ensures repeatable fuel-to-air ratio that leads to improved fuel economy and reduced carbon footprint.

- ✦ Able to reduce fuel consumption by 5-7% over traditional linkage systems
- ✦ Capable of reducing CO<sub>2</sub> emissions by 10%
- ✦ Repeatable and accurate positioning system reduces maintenance costs
- ✦ Controls fuel, VSD, scheduling, sequencing and other automatic settings
- ✦ Robust steel construction
- ✦ Available in a control panel package

# Main Screen

Actual fascia size (16.75 x 13.5cm)

Actual screen size (14 x 10.7cm)

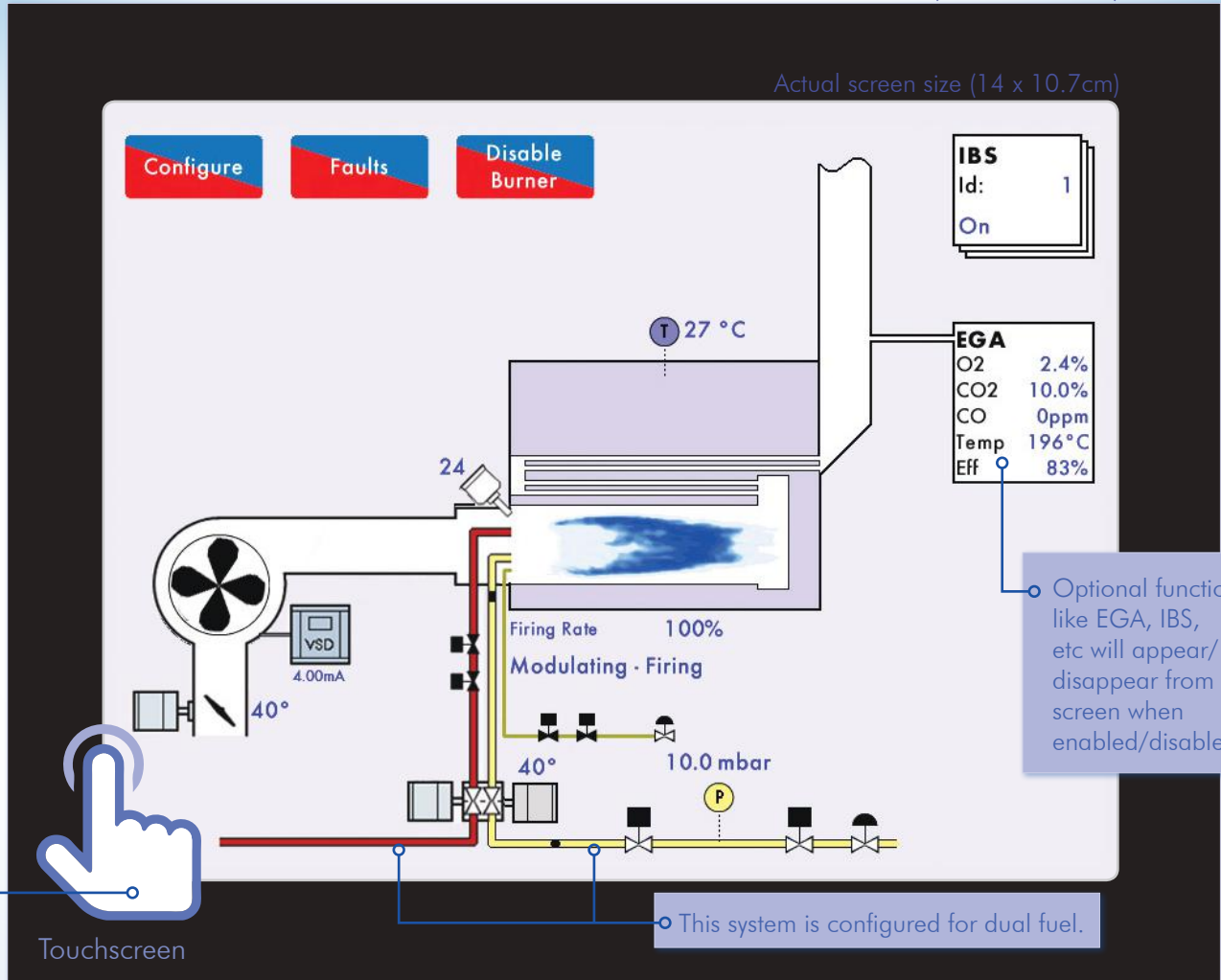

Touchscreen

The user can get back to this Main Screen from anywhere in the system with a few taps.

Navigate to advanced screens and history with the touch of a finger from the Main Screen.

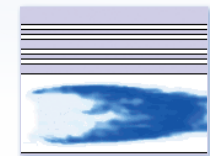

Steam Pressure or Water Temperature Setpoints



Flame Safeguard

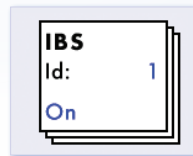

Intelligent Boiler Sequencing

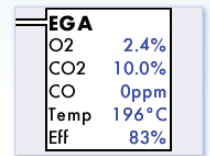

Exhaust Gas Analyser (Requires installation of EGA)

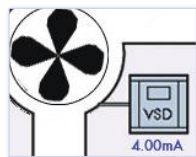

VSD (Variable Speed Drive)

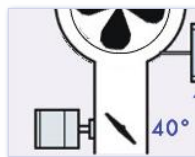

Air/Fuel Servomotors

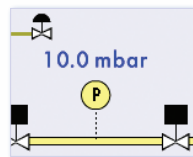

VPS (Valve Proving System)

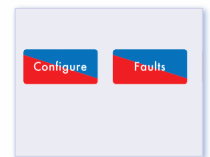

Online Settings & Fault History

# Schedule the boiler plant to run when and how you need it.

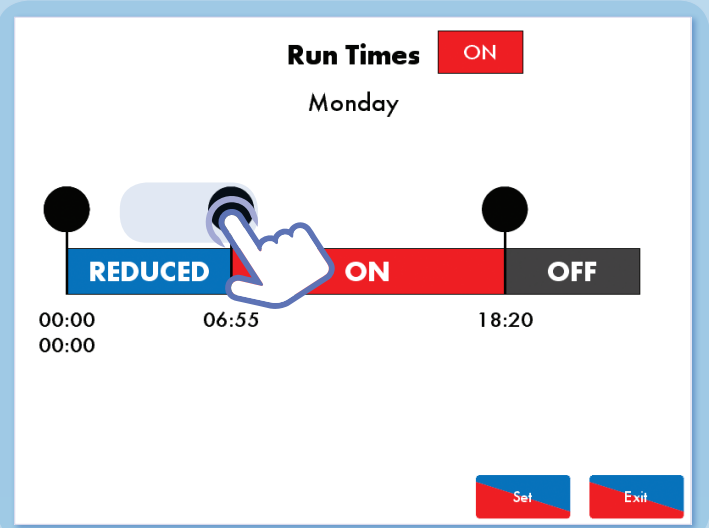

Drag slider to adjust timer. Tap to adjust function.

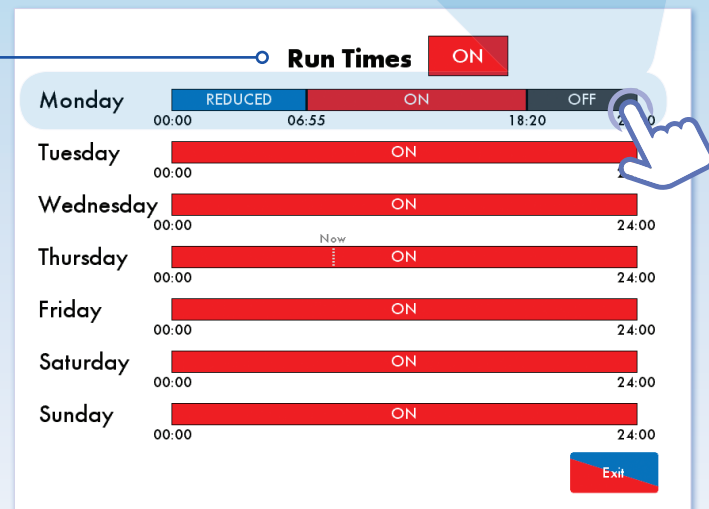

Schedule on, off and reduced (weekend) required temperature/pressure by day of week.

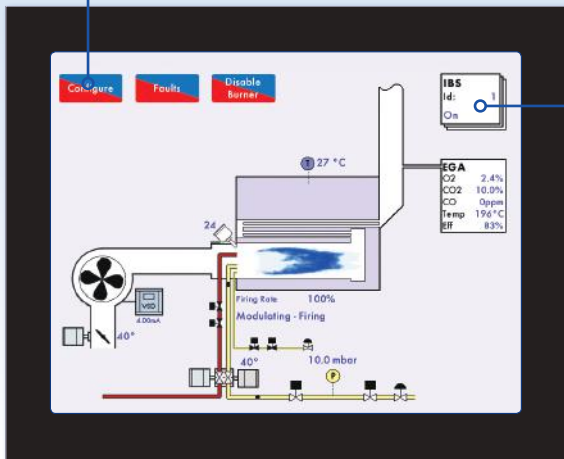

It is much more fuel efficient to run two boilers at 60% than three boilers at 20%. Intelligent Boiler Sequencing (IBS) manages the number of boilers firing at any given time, automatically taking unneeded boilers offline or into standby warming modes to maintain load demand. Users can manage up to 10 boilers.

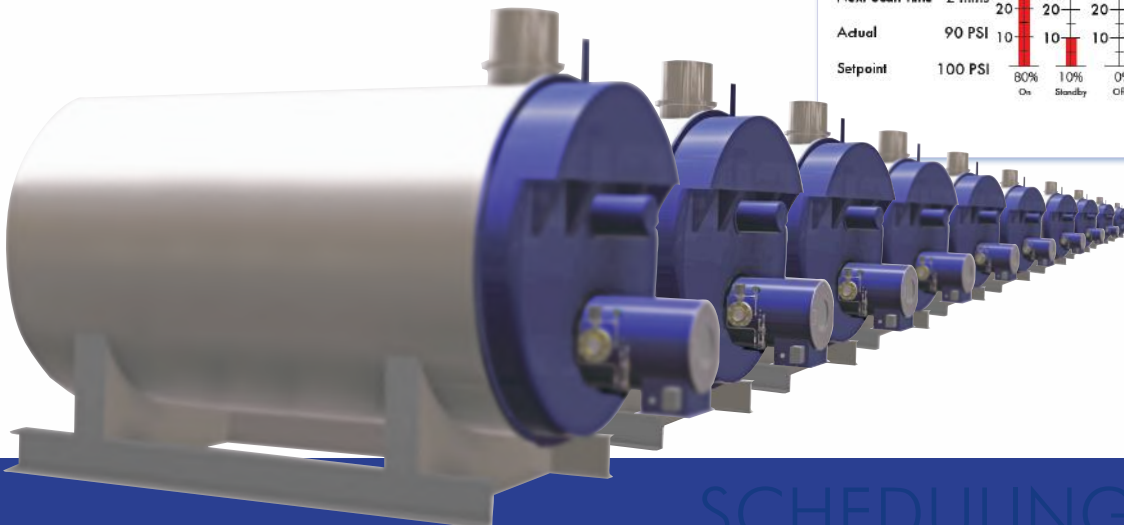
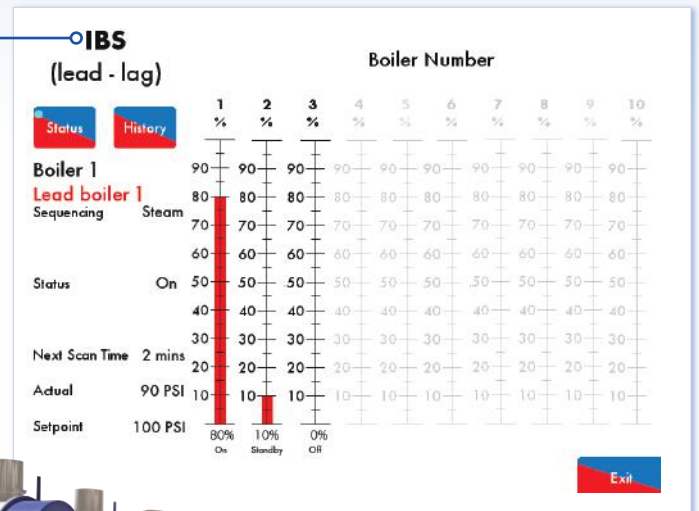

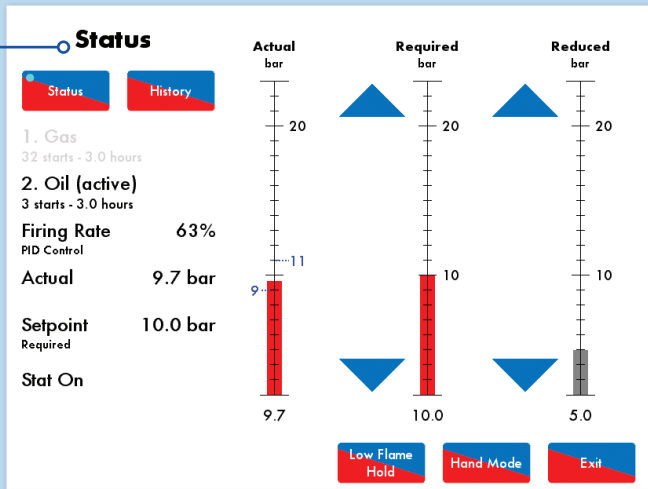

Easily change target set points for both the Required setpoints (used for general output) and the Reduced setpoints (used for when less steam or hot water is required).

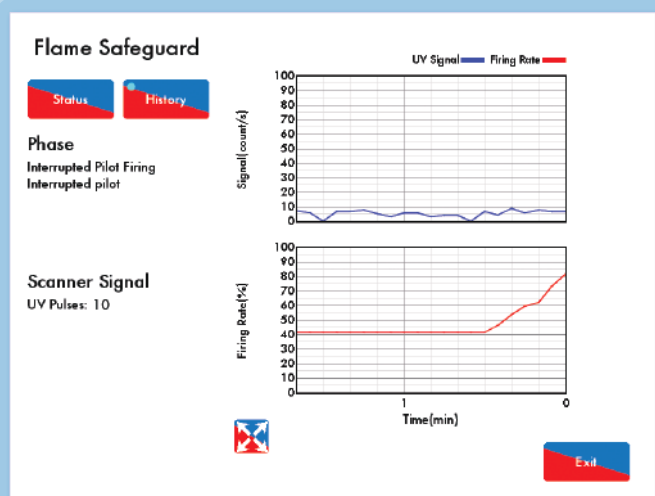

The flame is monitored via UV or IR scanner or ionization probe. The UV scanner can feature self-checking to cover an unmanned boiler house.

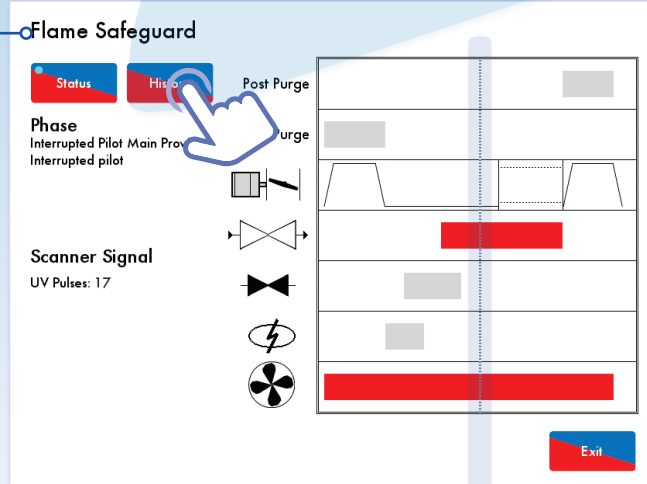
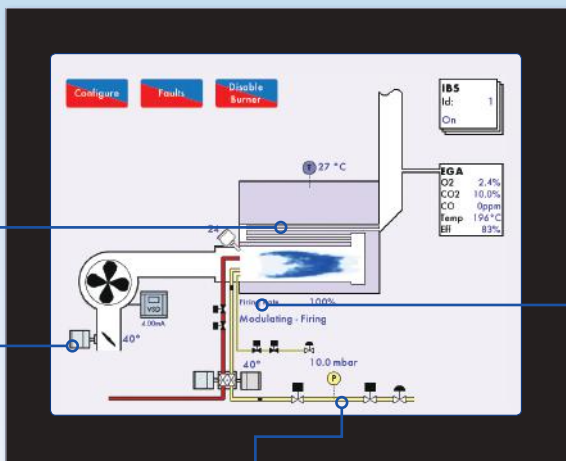

Flame Safeguard monitors & manages every stage of burner startup, including valve proving & IR/UV testing. Dotted vertical line slides right as the system advances through burner sequence.

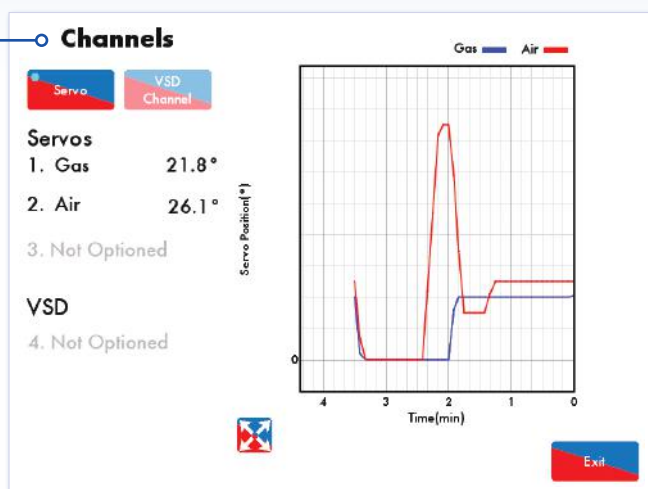

3 servomotors and 1 VSD provide accurate and repeatable control of valves and dampers. 24 hour on-screen history enables immediate troubleshooting and optimising.

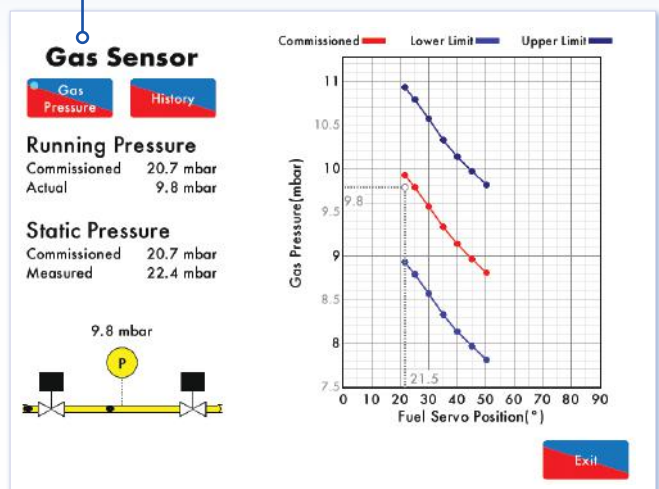

VPS (Valve Proving System) tests the main gas valves to ensure seal integrity and safety.

### Online Changes

#	Description	Value
110	BC: Burner flame scanner type	Standard scanner
111	BC: Pilot type	Interrupted pilot
112	BC: Pre-purge time	6 seconds
113	BC: Pre-ignition time	3 seconds
114	BC: First safety time	3 seconds
115	BC: Pilot prove time - pilot trial for ignition (PTR)	3 seconds
116	BC: Fuel 1 second safety time - main trial for ignition (MTR)	3 seconds
117	BC: Main flame proving time	5 seconds
118	BC: Post-purge time	10 seconds
119	BC: Control box recycle time	10 seconds
120	BC: UV Threshold	10
121	BC: Delay from start of pre-purge until air switch checked	5 seconds
122	BC: Flame switch operation	Ionisation
123	BC: Fuel 2 second safety time - main trial for ignition (MTR)	3 seconds

Thursday 29 Nov 2014 08:18:13

Over 150 options and parameters can be adjusted, providing a sophisticated level of customisation. All of these are viewable while the boiler is online. A selection of these changes can be set while the burner is running, ensuring minimum boiler downtime.

### Online Changes

Settings Restart MM

Options Parameters Restart MM in Standby

### Commission

Fuel-flow Commission

### Reset

Fuel 1 Burner History Fuel 1 Fuel Flow Fault Logs Boiler Config Confirm Reset

Fuel 2 Burner History Fuel 2 Fuel Flow System Log Run Times

Exit

A technician can view & modify a variety of settings without having to take the boiler offline, reducing boiler downtime.

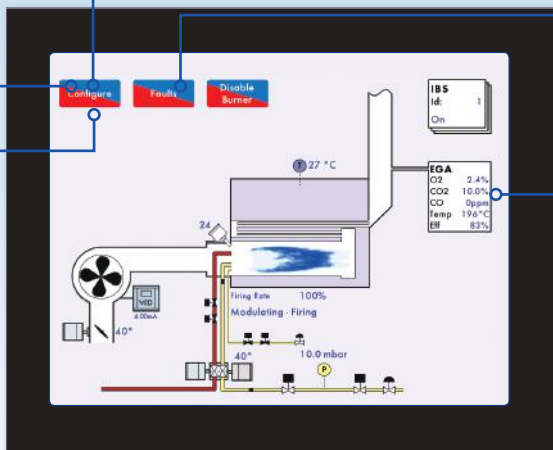

### Lockouts

	Phase	Occurred	Reset
1.	No flame signal	Pilot Ignition	29 Jan 2014 21:06 29 Jan 2014 21:08
2.	No air proving	Run to Ignition	26 Jan 2014 00:04 26 Jan 2014 00:04
3.	Start gas output fault	Pilot 1st Safety	25 Jan 2014 00:06 25 Jan 2014 00:14
4.	Start gas output fault	Pilot 1st Safety	24 Jan 2014 00:03 24 Jan 2014 00:03
5.	Start gas output fault	Pilot 1st Safety	23 Jan 2014 00:48 23 Jan 2014 00:03
6.	No air proving	Run to Purge	22 Jan 2014 00:01 22 Jan 2014 00:03
7.	No air proving	Run to Purge	17 Jan 2014 00:02 17 Jan 2014 00:03
8.	No air proving	Run to Purge	16 Jan 2014 00:02 16 Jan 2014 00:03
9.	No air proving	Run to Purge	14 Jan 2014 00:18 14 Jan 2014 20:03
10.	No air proving	Run to Purge	13 Jan 2014 00:01 13 Jan 2014 00:01

Lockouts MM Errors EGA Errors

Reset Exit

Error and Lockout logs allow engineers to view a history of burner operation to aid in troubleshooting. View the most recent 64 errors and lockouts.

### Single Point Change

Channel 1 0.0°

Channel 2 0.0°

Channel 3

Channel 4 20.0 mA CANCEL

### Starting Commissioning

Phase: Recycle  
Fuel: 1  
Stat: Off  
Actual: 20 °C

Phase Hold

Status Fuel - Air VSD EGA Trim

Single Point Change allows a technician to edit the combustion curve without the need of a full re-commissioning, reducing downtime.



The optional Exhaust Gas Analyser (EGA) enables three parameter trim features to maintain commissioned exhaust values. This ensures optimum burner operation at all times.

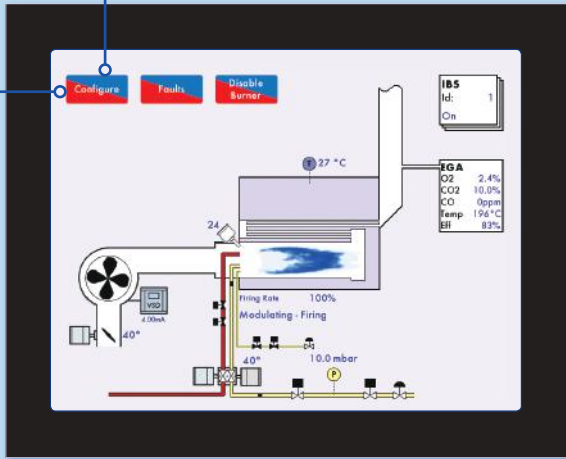

Capable of single servomotor control, modulating gas valve (and optionally VSD) for atmospheric boilers.

On-screen native language support allows users to control the boiler in English (UK or US), Chinese, German, Spanish, Turkish, Polish and other languages.

MM错误	发生	重置
1. (27.0) 负荷感应器错误	18 九月 2015 19:06	18 九月 2015 19:06
2. (27.0) 负荷感应器错误	26 八月 2015 15:49	26 八月 2015 15:50
3. (22.0) 燃烧机控制通讯错误	12 八月 2015 17:53	12 八月 2015 17:55
4. (27.0) 负荷感应器错误	24 七月 2015 13:47	26 七月 2015 19:48
5. (27.0) 负荷感应器错误	24 七月 2015 13:39	24 七月 2015 13:40
6. (27.0) 负荷感应器错误	24 七月 2015 13:38	24 七月 2015 13:39
7. (27.0) 负荷感应器错误	24 七月 2015 13:37	24 七月 2015 13:38
8. (27.0) 负荷感应器错误	24 七月 2015 13:37	24 七月 2015 13:37
9. (27.0) 负荷感应器错误	22 七月 2015 16:10	22 七月 2015 16:11
10. (27.0) 负荷感应器错误	9 七月 2015 11:30	9 七月 2015 11:30
11. (27.0) 负荷感应器错误	9 七月 2015 11:29	9 七月 2015 11:29
12. (27.0) 负荷感应器错误	9 七月 2015 11:26	9 七月 2015 11:28
13. (27.0) 负荷感应器错误	9 七月 2015 11:25	9 七月 2015 11:25
14. (27.0) 负荷感应器错误	9 七月 2015 11:24	9 七月 2015 11:24
15. (27.0) 负荷感应器错误	9 七月 2015 11:24	9 七月 2015 11:24
16. (27.0) 负荷感应器错误	9 七月 2015 11:22	9 七月 2015 11:23
17. (27.0) 负荷感应器错误	9 七月 2015 11:20	9 七月 2015 11:21

## Mk8 EGA EVO

Exhaust Gas Analyser (EGA)



## Enable trim & emissions monitoring

- ◆ Enables 3 parameter trim on Mk8 MM Controller for improved burning efficiency.
- ◆ Continuous Emissions Monitoring System (CEMS) for display & data trending. View reports by user-definable time periods (6 hours, 8 days, 500 days, etc.) based on:
  - ◆ Total weight & volumetric emissions
  - ◆ Total cost of fuel (calculated by current cost per tonne of fuel)
  - ◆ Weight & volumetric emissions per exhaust gas (O<sub>2</sub>, CO<sub>2</sub>, CO, NO, NO<sub>2</sub>, SO<sub>2</sub>) & per fuel
  - ◆ Specifically designed for current regulations on emissions monitoring
- ◆ MM Controller or Standalone Operation modes
- ◆ Six 4-20mA analogue outputs of all combustion data for remote logging, printing or chart recording

## Mk7 DTI

Data Transfer Interface (DTI)



## Remote monitoring, control & data storage

- ◆ View live streaming data of up to 10 boilers from a single DTI, through a local PC or BMS
- ◆ Enables BMS integration with the boiler plant via MODBUS and Ethernet
- ◆ View up to 150 items of information from each MM Controller and each EGA
- ◆ Stores up to 2 years of data history on all boilers

# Choosing the correct controller

The Mini Mk8 is ideal for budget applications focused mainly on burner control.

The Mk8 MM offers expandability and is focused on complete boiler control.



Standard Features	Mini Mk8 MM Controller	Mk8 MM Controller
Screen size	7" (14x10.7cm)	12.1" (24.5x18.5cm)
Touchscreen	Single-touch resistive	Multi-touch capacitive
Flame safeguard	✓	✓
Air/fuel ratio control	✓	✓
IBS/lead-lag sequencing	✓	✓
Scheduling	✓	✓
Commissioning	✓	✓
VSD management	✓	✓
Reporting/graphing	✓	✓
FGR (Flue Gas Recirculation)	✓	✓
Channels	3 servos/1 VSD	4 servos/2 VSD 5th servo via access code
Lockout/error logging	Most recent 64 errors/lockouts	Most recent 128 errors/lockouts
Number of fuel curves	2	4
VPS (Gas Valve Proving)	✓	✓
Outside temperature	✓	✓
Login security	✓	✓
Back up commissioning data via IR port	✓	✓
Boiler log entries	1000	1000
Dual fuel support	✓	✓
Air pressure monitoring & proving	✓	✓
Oil pressure monitoring	–	✓
Fuel flow metering	✓	✓
Golden start facility	✓	✓
Commissioning points	20	20
Customizable graphics	✓	✓
Flame rod/UV change over option	✓	✓
Multi-language interface (Chinese, Spanish, German, Italian, Polish, more...)	✓	✓
Metric/Imperial	✓	✓
UL, CE, AGA approvals	✓	✓
Single gas servo control for atmospheric boilers	✓	–
On-board technical manual	✓	✓

Available with software access code		
Direct Modbus connectivity	✓*	✓
Autoflame Water Level Management (AF WLM)	–	✓
Analogue water level management (requires AF WLM)	–	✓
Steam/heat flow metering	–	✓
Top blowdown/TDS	–	✓
Bottom blowdown	–	✓
Draft control	–	✓
First out annunciation	–	✓
Fully metered, cross-limited combustion control	–	✓

\*Mini Mk8 does not require access code

Requires additional module or component		
Indirect Modbus connectivity	Requires DTI	Requires DTI
O2 trim	Requires O2 Module	Requires O2 Module
Three parameter trim (O2, CO2, CO)	Requires EGA	Requires EGA
Emissions monitoring & reporting	Requires EGA	Requires EGA



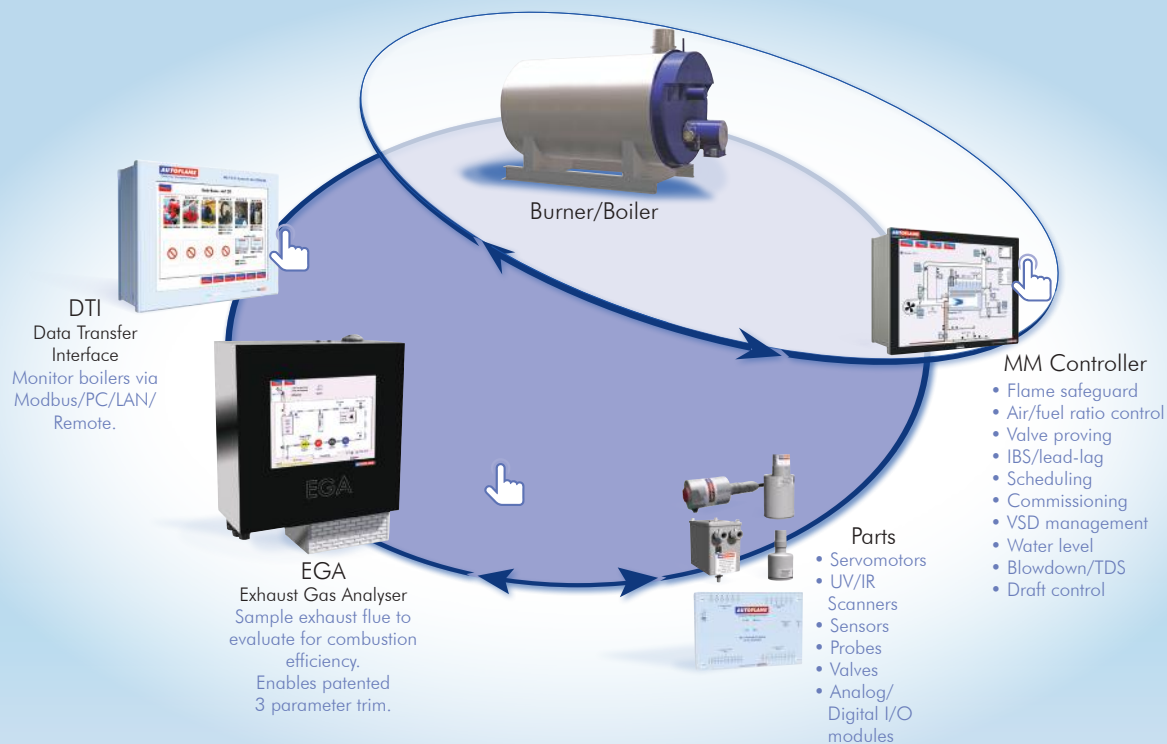

## Ancillary Equipment

Autoflame manufactures to the highest quality standards a range of servomotors, probes, scanners, sensors, valves and other parts to support its burner/boiler management system. These are all designed and manufactured in house to maintain the highest quality control.

## Local Installation & Support

Autoflame has partnerships with more than 95 Technology Centres worldwide. To maintain our reputation for quality, safety and reliability, Autoflame ensures they receive regular training to keep up to date with our latest innovations.

## About Autoflame

Founded in 1972, Autoflame is a world leader in boiler/burner management systems for both commercial and industrial applications. Based near London, England, it ensures industry-leading quality control and innovation by performing in-house R&D, engineering, software development, manufacturing production, and technical support.

Privately owned by its founder, Brendan Kemp, Autoflame currently has more than 10,000 systems in operation globally, and is now specified as standard equipment in some of the world's most prestigious organisations.

## Autoflame patents related to Boiler Automation, Efficiency & Safety

**Europe:** 1022515, 1373796, 1384944, 1384945, 1384946, 60014980.3, 60201594.4, 60202855.8, 60203002.1, 60203040.4, 09252836.3, 11778663.2, 1022515, 10151584.9

**UK:** 1022515, 1373796, 1384944, 1384945, 1384946, 2412958, 2448624, 2448625, 0823303.3, 0907125.9, 1018178.2, 1214740.1, 1318174.8, 0907125.9, 1018178.2

**USA:** 6024561, 6520122, 6978741, 12/946.615, 6024561, 7249573, 13/591922, 13/651029

**Canada:** 2295458

